

Maths Booster - Spark 7

Week - 1

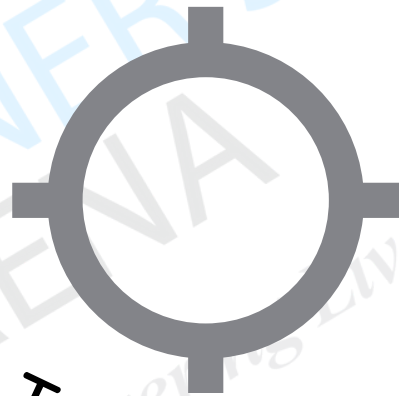

Expected Score



Target Score

Name :

School :

Section :

“Small daily practice, when done consistently, develops habits that lead to long-term success.”

Table of Content

- Circles
- Triangles
- Arithmetic Progressions
- Height & Distances
- Statistics

| | | |
|--------------------------|---------------------|-------|
| <input type="checkbox"/> | Directions | |
| <input type="checkbox"/> | Concept Drill (CD) | 1 |
| <input type="checkbox"/> | Formula Drill (FD) | 2 |
| <input type="checkbox"/> | Day 1 | 3-4 |
| <input type="checkbox"/> | Day 2 | 5-6 |
| <input type="checkbox"/> | Day 3 | 7-9 |
| <input type="checkbox"/> | Day 4 | 10-11 |
| <input type="checkbox"/> | Day 5 | 12-13 |
| <input type="checkbox"/> | Day 6 | 14-15 |
| <input type="checkbox"/> | Day 7 | 16 |
| <input type="checkbox"/> | Daily Analysis | 17 |
| <input type="checkbox"/> | Topic-wise Analysis | 18 |

Directions

- Write your Expected Score & Target Score honestly.
- Keep a geometry box, rough notebook, and formula sheet ready.
- Identify & Write the Topic, Concept, and Formulas used for every question.
- Follow the given Step-marking scheme:

| Steps Expected | CBSE Marks |
|----------------|------------|
| 3-4 Steps | 1-2 marks |
| 6-7 Steps | 3 marks |
| 8-9 Steps | 4 marks |
| 12-14 Steps | 5 marks |

Scan the QR for detailed instructions video



“Practice turns concepts into clarity.”

Concept Drill (CD)

1. The tangent at any point of a circle is perpendicular to the radius through the point of contact.

Draw a fully labelled figure (if possible, freehand).



2. There are exactly 2 tangents to a circle through a point lying outside the circle.

Draw a fully labelled figure (if possible, freehand).



3. What can you tell about the length of the tangents and the angle formed by the tangents?

Formula Drill (FD)

1. Standard form of a Quadratic Equation: $ax^2 + bx + c$

2. Nature of Roots $Discriminant (D) = b^2 - 4ac$

2 distinct Real roots

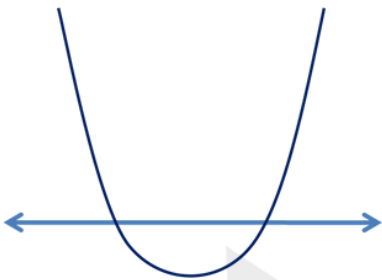

$$b^2 - 4ac > 0$$

only One Real root
OR

2 equal Real roots



$$b^2 - 4ac = 0$$

No Real root
OR

Imaginary roots

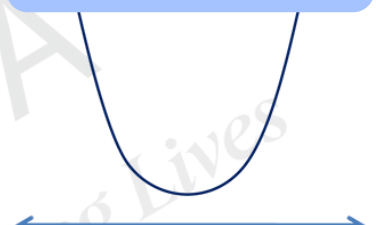

$$b^2 - 4ac < 0$$

$$Roots (x_1, x_2) = \frac{-b \pm \sqrt{b^2 - 4ac}}{2a}$$

3. Sum of Roots: $x_1 + x_2 = \frac{-b}{a}$

4. Product of Roots: $x_1 \times x_2 = \frac{c}{a}$

1. Two tangents AB and AC are drawn to a circle with centre O such that $\angle BAC = 60^\circ$. Then OA = ?

- A) 2OB
- B) 2AB
- C) 3AC
- D) 2AC

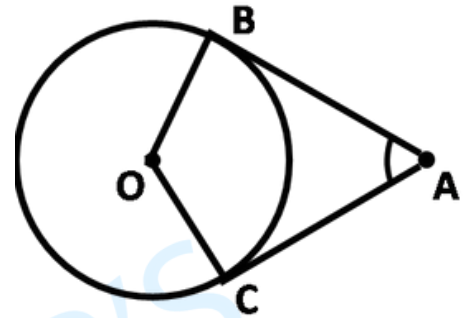

Freehand Labelled Figure; Topic & Concept 3-4 Steps

2. The mean of 1, 3, 3, 5, 8, 4 is m. The numbers 3, 2, 1, 4, 5, 2, p have mean $m - 1$, and median _____.

Topic & Concept; Formulas used 3-4 Steps

3. In the figure given the circle touches all the four sides of the quadrilateral PQRS whose three sides are $PQ = 7$ cm, $QR = 6$ cm, $RS = 4$ cm, then find the length of PS.

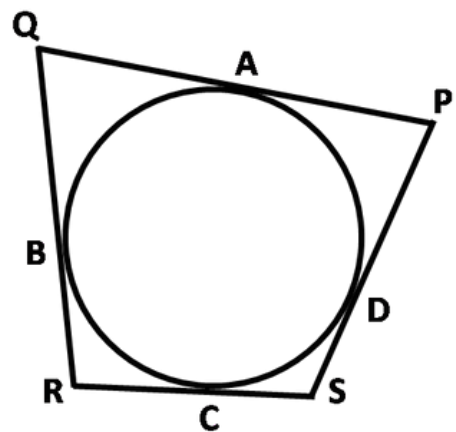

Freehand Labelled Figure; Topic & Concept 6-7 Steps

Day - 1

4. The mean of 6 numbers is 21. If one of the number is excluded the new mean is 19. Find the value of the excluded number.

Topic & Concept; Formulas used

6-7 Steps

5. A fighter jet takes off from the ground, making an angle of 60° with the horizontal and reaching a vertical height of $2\sqrt{3}$ km in 20 seconds. After reaching this height, the jet changes its direction and ascends further at an angle of 45° with the horizontal. During this second phase, the plane moves at double the speed of the initial phase for the next 10 seconds.

Freehand Labelled Figure; Topic & Concept 12-14 Steps

- Find the distance travelled by the jet along its path during the first 20 seconds.
- Calculate the speed of the jet during the first phase of its ascent.
- Find the distance travelled by the jet in the next 10 seconds during the second phase of ascent.
- Calculate the additional vertical height gained by the jet during the second phase and hence find the total height of the jet from the ground after 30 seconds.

End Time: _____

Day - 2

Start Time: _____

1. In the formula $\bar{x} = a + \frac{\sum x_i d_i}{\sum f_i}$ for finding the mean of ground data d_i 's are the deviation from 'a' of:
- A) lower limits of the classes
 - B) upper limits of the classes
 - C) mid-points of the classes
 - D) frequencies of the class marks

Topic & Concept; Formula used

3-4 Steps

2. PQ is a tangent to a circle with centre O at point P. If $\triangle OPQ$ is an isosceles triangle then find $\angle OPQ$.

Freehand labelled figure; Formulas used

3-4 Steps

3. Find the sum of the lower limits of the median class and the modal class for the following distribution:

| | | | | | |
|-----------|-----|------|-------|-------|-------|
| Class | 0-5 | 5-10 | 10-15 | 15-20 | 20-25 |
| Frequency | 10 | 15 | 12 | 20 | 9 |

Topic & Concept; Formula used

6-7 Steps

Day - 2

4. Prove that the parallelogram circumscribing a circle is a rhombus.

Freehand labelled figure; Topic & Concept 8-9 Steps

5. Rohit plans to save money every month to buy a new laptop. In the first month, he saves ₹500. Every subsequent month, he increases his savings by ₹200 more than the previous month.

Topic & Concept; Formula used 12-14 Steps

- a) Write the Arithmetic Progression (AP) representing Rohit's monthly savings. Also, write the first term (a) and the common difference (d).
- b) Find the amount Rohit saves in the 10th month.
- c) Calculate the total amount saved by Rohit in 12 months.
- d) If the cost of the laptop is ₹24,000, determine whether Rohit can buy the laptop after 12 months. Justify your answer with calculation.

End Time: _____

1. In the figure given below, $\angle BAC = 90^\circ$ and $AD \perp BC$. Then:

- A) $BD \times CD = BC^2$
- B) $AB \times AC = BC^2$
- C) $BD \times CD = AD^2$
- D) $AB \times AC = AD^2$

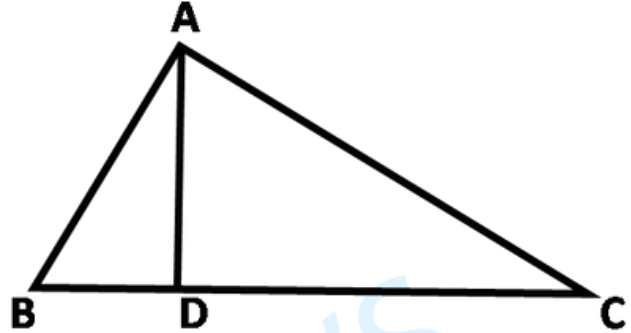

Freehand labelled figure; Topic & Concept 3-4 Steps

2. From a point P, which is at a distance of 25 cm from the centre O of a circle of radius 7 cm, the pair of tangents PQ and PR to the circle is drawn. Then find the area of quadrilateral PQOR.

Freehand labelled figure; Formulas used 3-4 Steps

3. In the figure, quadrilateral ABCD is circumscribing a circle with centre O and $AD \perp AB$. If the radius of incircle is 10 cm, then find the value of x.

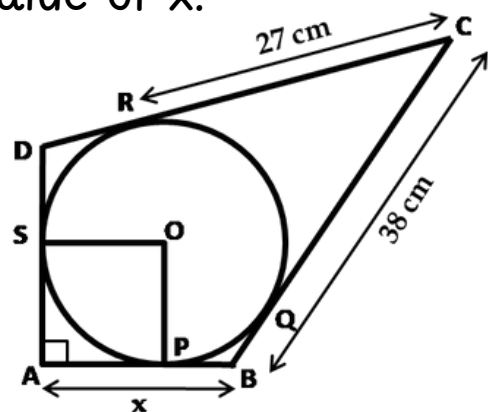

Freehand labelled figure; Formula used 6-7 Steps

Day - 3

4. In the given figure, $\angle D = \angle E$ and $\frac{AD}{DB} = \frac{AE}{EC}$.
Prove that $\triangle BAC$ is an isosceles triangle.

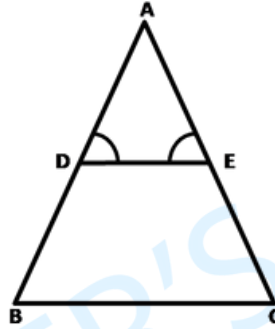

Freehand labelled figure; Topic & Concept 8-9 Steps

5. Two palm trees are of equal height and are standing opposite each other on either side of the river, which is 80m wide. From a point O between them on the river, the angles of elevation of the top of the trees are 60° and 30° respectively.

Freehand labelled figure; Formula used 12-14 Steps

- Find the height of the trees.
- The distances of the point O from the trees.
- A monkey is sitting at the top of the tree that subtends an angle of 60° at point O. After some time, the monkey climbs downwards and stops at a point on the same tree such that the angle of elevation of the monkey from point O becomes 45° . Find the vertical distance descended by the monkey.

End Time: _____

Day - 3 Challenge

Start Time: _____

1. In the following figure, A, B, P, and Q are points of contact of direct common tangents of the two circles. If $\angle ACB$ is 120° , then find the angle between the two tangents and the angle made by PQ at the centre of the same circle.

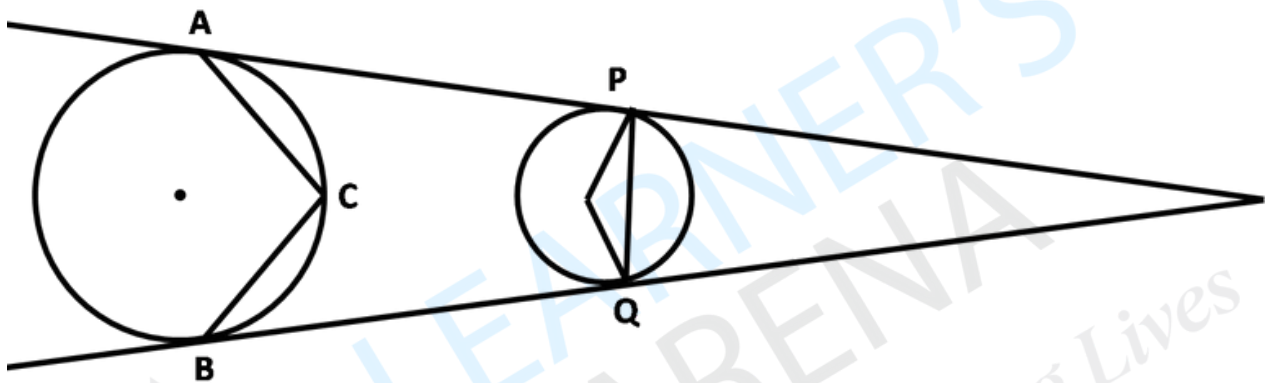

Freehand labelled figure; Topic & Concept

8-9 Steps

2. In the following figure, O is the centre of the circle, AB and CD are equal chords. If $\angle AOB$ is 100° , then find the angle $\angle CED$.

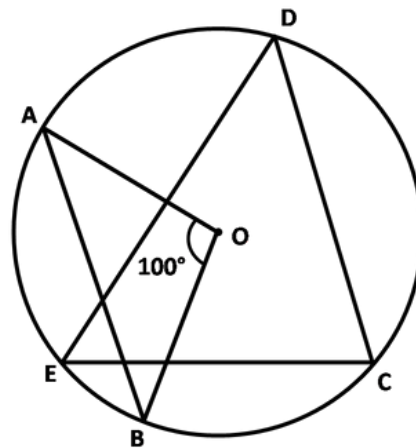

Freehand labelled figure; Topic & Concept

8-9 Steps

End Time: _____

1. 11th term of the A.P.: -3, -0.5, 2, ___ is:

A) 28

B) -38

C) 22

D) -42.5

Topic & Concept; Formulas used

3-4 Steps

2. The angle of elevation of the top of a tower from a point C on the ground, which is 30 m away from the foot of the tower, is 30° . Find the height of the tower.

Freehand labelled figure; Formulas used

3-4 Steps

3. The tops of two towers of height x and y , standing on the ground, subtend the angles of 30° and 60° , respectively, at the centre of the line joining their feet then find $x : y$.

Freehand labelled figure; Formula used

6-7 Steps

4. Find the number of natural numbers between 109 and 1008 that are divisible by both 2 and 7.

Topic & Concept; Formula used

8-9 Steps

5. The shadow of a tower standing on a level ground is found to be 40m longer when the Sun's altitude is 30° , than when it was 60° . Find the height of the tower.

Freehand labelled figure; Formula used

8-9 Steps

Day - 4

6. Find the median of the data, using an empirical relation when it is given that the Mode = 12.4 and the Mean = 10.5.

Topic & Concept; Formulas used

6-7 Steps

7. Find the missing frequency 'f' in the following table, if the mean of the given data is 18. Hence find the mode.

| Daily Allowance | No. of Children |
|-----------------|-----------------|
| 11 - 13 | 7 |
| 13 - 15 | 6 |
| 15 - 17 | 9 |
| 17 - 19 | 13 |
| 19 - 21 | f |
| 21 - 23 | 5 |
| 23 - 25 | 4 |

Topic & Concept; Formula used

12-14 Steps

End Time: _____

Day - 5

4. In $\triangle ABC$, if $AD \perp BC$, and $AD^2 = BD \times DC$, then prove that $\angle BAC = 90^\circ$.

Topic & Concept; Formulas used

8-9 Steps

5. A brooch is a decorative piece often worn on clothing like jackets, blouses, or dresses to add elegance. Made from precious metals and decorated with gemstones, brooches come in many shapes and designs.

One such brooch is made with silver wire in the form of a circle with a diameter of 35 mm. The wire is also used in making 5 diameters, which divide the circle into 10 equal sectors as shown in the figure.

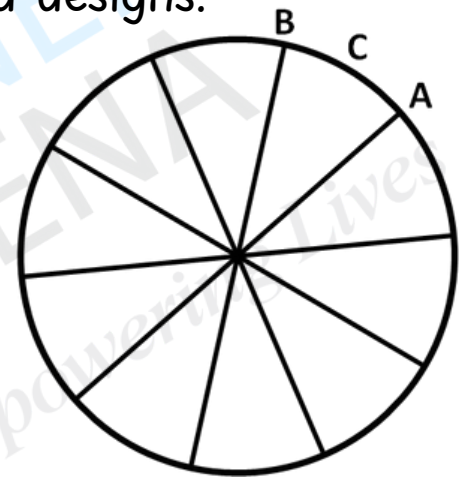

- Find the central angle of each sector.
- Find the length of the arc ACB.
- Find the area of each sector of the brooch.
- Find the total length of the silver wire used.

Topic & Concept; Formula used

12-14 Steps

End Time: _____

1. in the following figure, $DE \parallel BC$. Find the value of x .

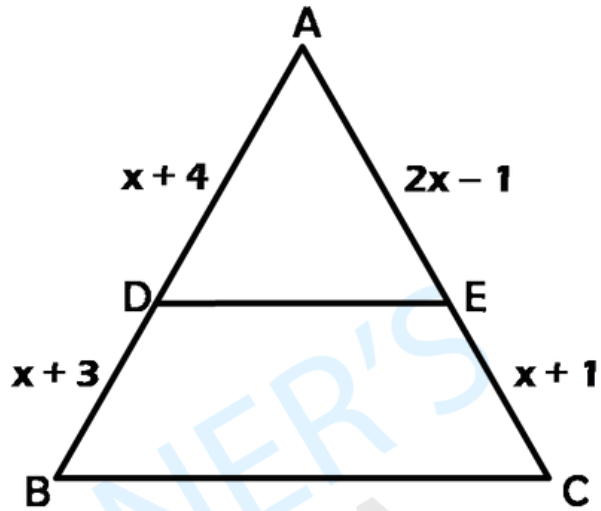

Topic & Concept; Formulas used

3-4 Steps

2. The sum of all the terms of an AP having ten terms except for the 1st term is 103, and except for the 6th term is 78. Find the 8th term of, if the sum of 2nd and 4th term is 26.

Topic & Concept; Formula used

6-7 Steps

3. A thief runs away from a police station at a uniform speed of 100 m/minute. After 1 minute, a policeman runs behind the thief to catch him. He goes at a speed of 100 m/minute in the first minute and increases his speed by 10 m each succeeding minute. After how many minutes, the policeman will catch the thief?

Topic & Concept; Formula used

8-9 Steps

Day - 6

4. In $\triangle ABC$, a line segment XY is drawn parallel to side AC of the triangle. It divides the triangle into two parts of equal area. Then find, $AX : AB$.

Freehand labelled figure; Topic & Concept; 8-9 Steps

5. A stopwatch was used to find the time that it took a group of students to run 100 m.

| | | | | | |
|---------------|------|-------|-------|-------|--------|
| Time (in sec) | 0-20 | 20-40 | 40-60 | 15-20 | 80-100 |
| Students | 10 | 15 | 12 | 20 | 9 |

Read the given data and answer the following questions.

- Estimate the mean time taken by a student to finish the race.
- What will be the upper limit of the modal class?
- Cumulative frequency table is used to find which type of central tendency.
- What is the sum of lower limits of the median class and modal class?

Topic & Concept; Formula used 12-14 Steps

End Time: _____

Day - 7 Challenge

Start Time: _____

1. If the sum of '2n' terms of the A.P. 2, 5, 8, 11,... is equal to the sum of 'n' terms of A.P. 57, 59, 61, 63, ..., then find the value of 'n'.

Topic & Concept; Formula used

8-9 Steps

2. From a point on the ground which is at a distance of 60 m from the foot of the tower, the angle of elevation to the top of the tower is observed to be 60° . After moving d m away from the tower, the angle of elevation of the top of the tower is decreased to 30° , then find the value of 'd'.

Freehand labelled figure; Topic & Concept

8-9 Steps

3. The 59^{th} term of an A.P. is 449, and the 449^{th} term is 59. Which term is equal to 0?

Topic & Concept; Formula used

8-9 Steps

4. AB is a chord of length 24 cm of a circle of radius 13 cm. The tangents at A and B intersect at a point C. Find the length AC.

Freehand labelled figure; Topic & Concept

8-9 Steps

End Time: _____

Daily Progress Tracker

| Day | Score | Best Que | Worst Que | Effort Score |
|---------|-------|----------|-----------|--------------|
| Day - 1 | | | | |
| Day - 2 | | | | |
| Day - 3 | | | | |
| Day - 4 | | | | |
| Day - 5 | | | | |
| Day - 6 | | | | |
| Day - 7 | | | | |
| Average | | | | |

*Rate your Effort Score honestly out of 10.

Topic-wise Analysis

| Topic | Correct / Incorrect | Error-log | Common Mistake | Remedial Learning |
|---------------------|---------------------|-----------|----------------|-------------------|
| Circles | | | | |
| Heights & Distances | | | | |
| A.P. | | | | |
| Triangles | | | | |
| Statistics | | | | |